

Dehumidifier Recusorb **RL-61, 61 ICE, 61L, 61L ICE**



Dehumidifying capacity at 20°C / 60%RH

7,5 - 11,5 kg/h

Dry air flow

1300 - 2100 m³/h

- Excellent performance in all climates
- Built-in heat recovery
- Duct connection
- F7 filter
- Stainless steel chassis and panels
- Highly efficient D-MAX rotor
- Options:
 - Frequency inverter to control airflows
 - Filter guard
 - Linear capacity control
 - Panel mounted humidity / dew point controller
 - Insulated inlets to help prevent condensation



Section of a dehumidifier rotor from Seibu Giken. The high number of channels means that moisture is adsorbed with extra efficiency.

World leaders in dehumidification.

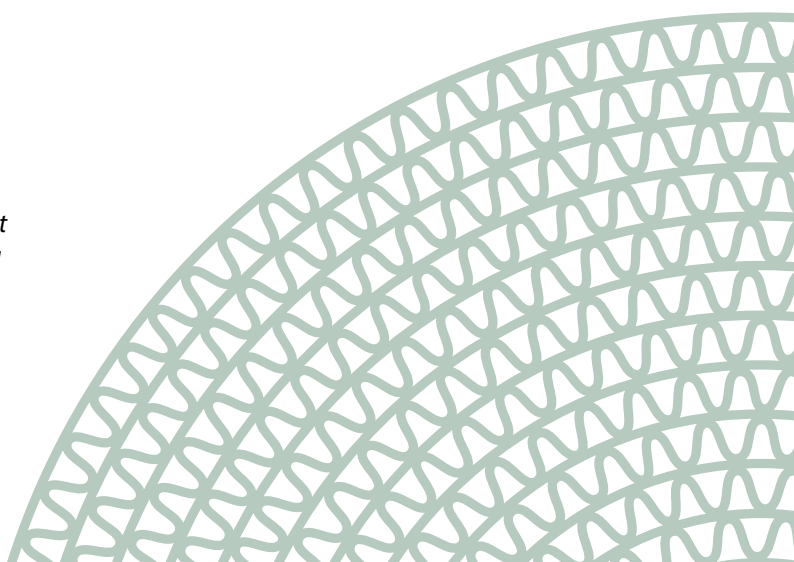

TECHNICAL DATA

Dehumidifier model	RL-61	RL-61 ICE	RL-61L	RL-61L ICE
Nominal capacity ¹ (kg/h)	7,5	8	11	11,5
Dry air flow ² (m ³ /h)	1300	1600	1800	2100
Static pressure at disposal (Pa)	650	600	400	500
Wet air flow ² (m ³ /h)	280	280	420	420
Static pressure at disposal (Pa)	300	300	300	300
Heater power (kW)	9	9	13,5	13,5
Total power (kW)	10,2	10,9	15,6	16,3
Supply fuse 3 x 400V 50Hz (A)	25	25	25	32
Weight (kg)	130	130	132	132

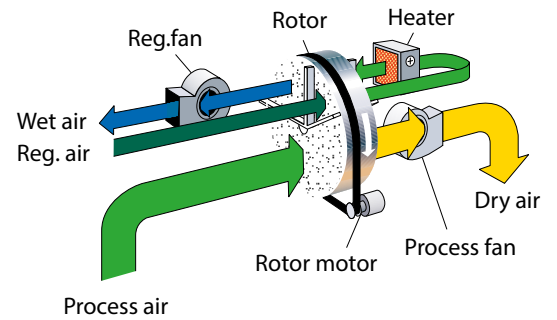

- Valid for inlet conditions 20°C/60%RH. For other inlet conditions the capacity can be calculated by using the correction diagrams shown below.
- Volume flow for density 1.20 kg/m³.

CORRECTION DIAGRAM

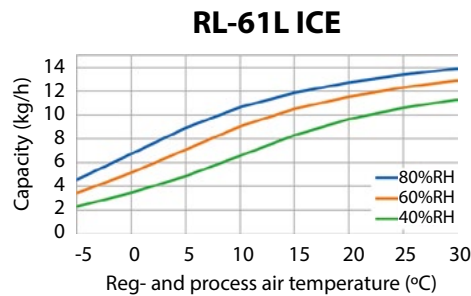
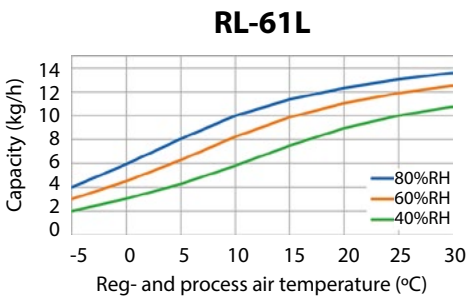
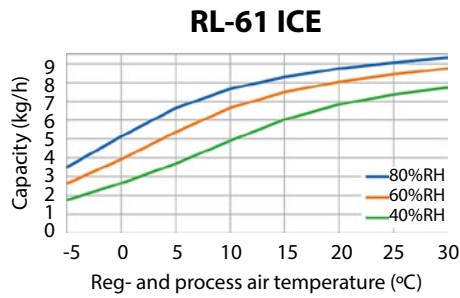
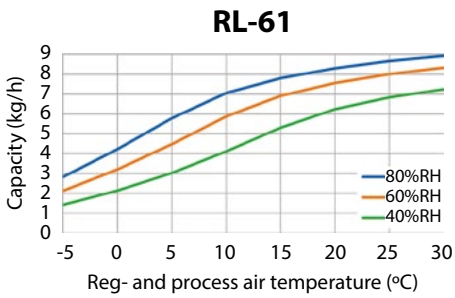

The temperature of the dry air at nominal air flows is calculated by: (Where C is the capacity in kg/h from above diagram).

RL-61:

$$T_{out} = T_{in} + C \times 1,6 + 3$$

RL-61 ICE:

$$T_{out} = T_{in} + C \times 1,3 + 3$$

RL-61L:

$$T_{out} = T_{in} + C \times 1,2 + 3$$

RL-61L ICE:

$$T_{out} = T_{in} + C + 3$$

DIMENSIONS

Subject to change without notice. Download installation drawing at www.dst-sg.com

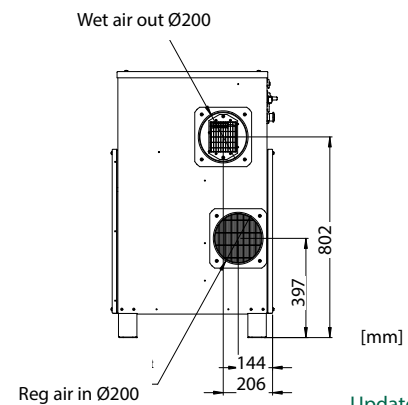
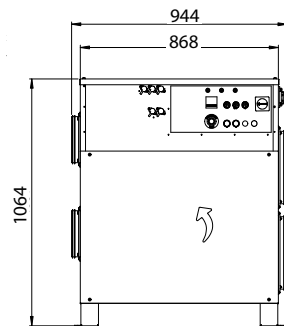
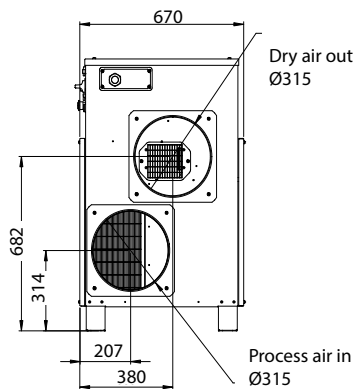

Updated 24.10